

FEATURES

- Full port, 1/2"~4" (DN15~DN100) -
- W.P. : 1000 WOG (PN63)
- W.T. : -20°C~200°C (-4°F~392°F) -
- Investment casting
- Blow-out proof stem
- Live-loading design
- Locking device
- Anti-static device
- ISO 5211 Direct mounting pad
- Length conform to DIN 3202/4-M3-2013ND-M3 (option)
- ISO 15848 fugitive emission approved (option)
- Automation accessories (option)

- Thread type : ASME B1.20.1 (NPT)
DIN2999 & BS21
ISO7/1 & EN10226

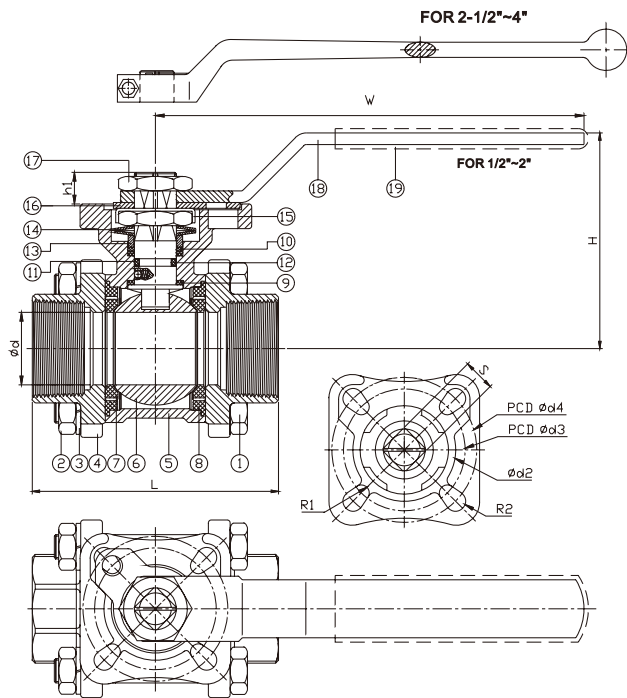

ITEM	PARTS	MATERIAL
1	BOLT	AISI 304
2	BOLT NUT	
3	SPRING WASHER	
4	CAP	ASTM A351-CF8M
5	BODY	
6	BALL	PTFE / RTFE
7	SEAT	
8	SEAL	PTFE
9	THRUST WASHER	
10	PACKING	VITON
11	O-RING	
12	STEM	ASTM A276-316
13	GLAND RING	AISI 304
14	BELLEVILLE WASHER	
15	LOCKING WASHER	
16	LOCKING DEVICE	
17	STEM NUT	
18	HANDLE	PVC
19	HANDLE SLEEVE	

DN	d	L	H	W	S	h1	d2	d3	d4	R1	R2	Weight (kg)	Torque (N-M)
15	15	65	60	120	9	8.5	31	36	42	2.75	2.75	0.6	7.5
20	20	75	64	120	9	8.5	31	36	42	2.75	2.75	0.7	11
25	25	85	74	148	11	11	35.5	42	50	2.75	3.5	1.1	14
32	32	101	79	148	11	11	35.5	42	50	2.75	3.5	1.7	21
40	38	112	95	178	14	13.5	56	50	70	3.5	4.5	2.6	27
50	50	130	103	178	14	13.5	56	50	70	3.5	4.5	3.7	50
65	63	162	123	325	17	20.5	76	70	102	4.5	5.5	7.1	85
80	76	188	131.5	325	17	20.5	76	70	102	4.5	5.5	10.2	97
100	96	224	165.5	325	22	22.5	100	102	125	5.5	6.5	19.4	150

unit:mm

NPS	d	L	H	W	S	h1	d2	d3	d4	R1	R2	Weight (lb)	Torque (in-lb)
1/2"	0.59	2.56	2.36	4.72	0.35	0.33	1.22	1.42	1.65	0.11	0.11	1.2	66.4
3/4"	0.79	2.95	2.52	4.72	0.35	0.33	1.22	1.42	1.65	0.11	0.11	1.6	97.4
1"	0.98	3.35	2.91	5.83	0.43	0.43	1.4	1.65	1.97	0.11	0.14	2.4	123.9
1-1/4"	1.26	3.98	3.11	5.83	0.43	0.43	1.4	1.65	1.97	0.11	0.14	3.7	185.9
1-1/2"	1.5	4.41	3.74	7.01	0.55	0.53	2.2	1.97	2.76	0.14	0.18	5.7	239
2"	1.97	5.12	4.06	7.01	0.55	0.53	2.2	1.97	2.76	0.14	0.18	8.2	442.5
2-1/2"	2.48	6.38	4.84	12.8	0.67	0.81	2.99	2.76	4.02	0.18	0.22	15.7	752.3
3"	2.99	7.4	5.18	12.8	0.67	0.81	2.99	2.76	4.02	0.18	0.22	22.5	858.5
4"	3.78	8.82	6.52	12.8	0.87	0.89	3.94	4.02	4.92	0.22	0.26	42.8	1327.6